

INCRA LS POSITIONER

INCRA'S PATENTED LEAD SCREW TECHNOLOGY FOR THE ULTIMATE IN PRECISION WOODWORKING CAPABILITY

OWNER'S MANUAL

Please read this owner's manual and keep it at hand for reference.

From typical fence system applications such as grooving, dadoing, rabbeting, edge forming, and ripping to advanced joinery functions, your new INCRA LS Positioner represents the ultimate in quality precision tooling for your dream shop. Inkra's patented lead screw driven positioning element sets a new standard for positioning accuracy guaranteeing fence placement to within two thousandths of an inch over the full range of the fence with zero repeatability error.

This translates to perfect cutting results, regardless of skill level – first time, every time. If you are interested in joinery for your next project, you need not look further than your new LS Positioner for superior box joint and dovetail capability. Whether you are cutting a simple equally spaced box joint, or the exquisite INCRA Double Dovetail, you'll find the simplicity of our template guided joinery system makes other joint making tools obsolete.

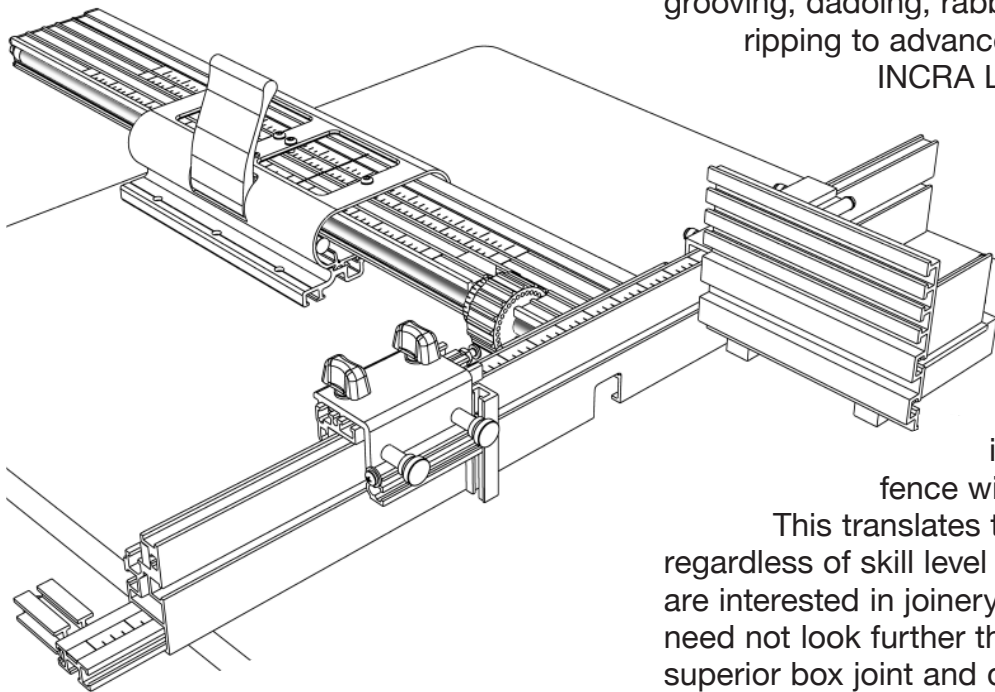

CONTENTS

Systems Configurations	2	Shop Stop	10
Safety	4	Operation	12
Getting Acquainted	4	Applications	14
Setup	5	Adjustments	14
Pro II Fence Installation	6	Auto Centering Scale	15
Wonder Fence Installation	8	Warranty	16

LS Positioner "Standard System"

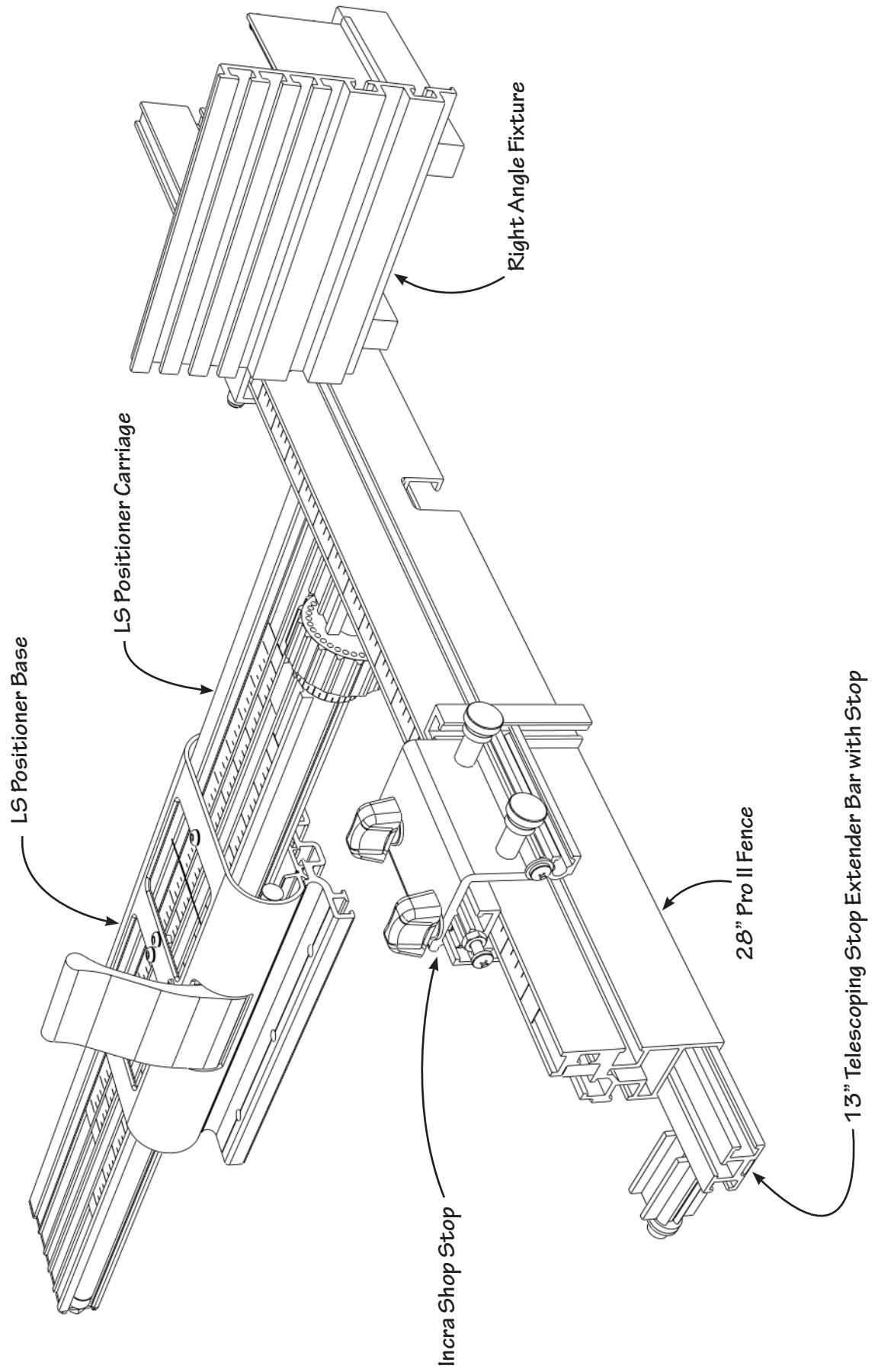

LS Positioner "Super System"

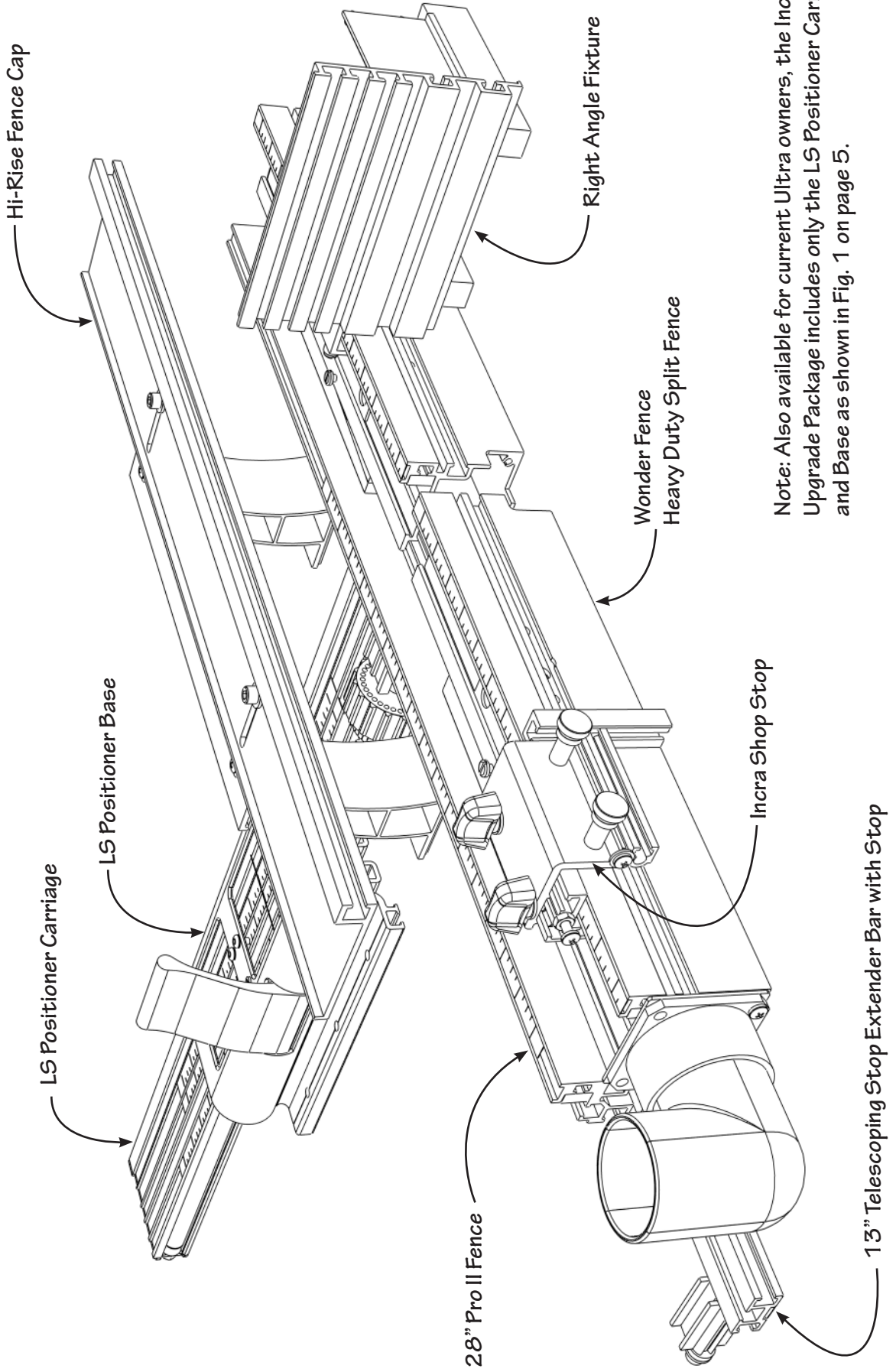

Note: Also available for current Ultra owners, the Incra LS Upgrade Package includes only the LS Positioner Carriage and Base as shown in Fig. 1 on page 5.

SAFETY

Important safety instructions for using the INCRA LS Positioner

- Before using the INCRA LS Positioner, read and follow all of the instructions and safety information in this manual.
- When using the INCRA LS Positioner in conjunction with any other tool, first read and follow all instructions and safety information in that tool's owner's manual.
- When mounted to a table surface, make sure that all of the mounting screws are securely tightened and the INCRA LS Positioner is firmly held in place.
- Always turn off the power and make sure that the bit or blade is fully stationary before moving the INCRA LS Positioner to any new setting.
- Always keep both hands behind the fence when moving the INCRA LS Positioner to a new setting.
- Before making a cut, always make sure that the carriage clamp is fully engaged and the fence is securely locked in place.
- When using the INCRA LS Positioner with other tools, make sure that all safety guards and other safety equipment supplied by the manufacturer of that tool are securely in place and functional. Never let the INCRA LS Positioner interfere with another tool's safety equipment.
- Use appropriate safety devices. Keep hands clear of the bit or blade. Always use a push stick, rubber soled push block, or other safety device to keep your hands safely away from the cutting tool.
- Wear safety glasses, hearing protection and follow all normal shop safety practices.
- DO NOT alter or modify the INCRA LS Positioner in an attempt to use it with non-INCRA accessories.
- Never let the bit or blade come into contact with any part of the INCRA LS Positioner, INCRA Shop Stop, or INCRA Right Angle Fixture.

GETTING ACQUAINTED

Before setting up and using your new INCRA LS Positioner, take a few moments to become better acquainted with the tool by reviewing the following component descriptions and the illustration in **Fig. 1**.

❶ Lead Screw Positioning Element

The LS Positioner obtains its great accuracy and repeatability from the precision lead screw, which positions the fence in exact increments of $\frac{1}{32}$ " (1mm metric version.)

❷ Auxiliary Scale Slots

Four auxiliary scale slots are provided to allow additional setups and cutting operations to take place without altering the primary scale position. Simply slide the supplied $\frac{1}{32}$ " or 1mm "floating" scale into position as needed for reference. The friction fit holds the scales securely during cutting operations. These extra slots are great for advanced joinery using the INCRA templates. You can even leave your most frequently used joinery templates from the optional INCRA Master Reference Guide & Template Library permanently installed.

❸ Three-Position Carriage Clamp

By pushing the carriage clamp down into the "unlocked" position, the carriage is free to glide to the next setting. Pull the clamp up to the center position for micro adjusting. Pull the clamp up to the final position and the carriage is locked solidly in place.

❹ Hairline Cursor and View Windows

The large hairline cursor and view windows provide a clear visual reference of the fence location and span the width of the carriage top and all five scale slots. The factory placement of the cursor can be moved to the rear view window location for use on smaller router tables.

❺ LS Base

The LS Base contains the threaded segment that engages with and functions to locate the carriage. It also houses the three-position carriage clamp, the hairline cursor, and view windows.

❻ Carriage

The reinforced square tube design of the carriage provides the ultimate in strength and support for your fence. It supports the lead screw positioning element and the micro adjust knob.

❼ Stainless Steel Primary Scale

After setting up your INCRA LS Positioner and "zeroing" to the bit or blade, position this scale to read 0" under the hairline cursor. Use this scale as the primary source for readout of fence to bit or blade distance.

8 Fence Mounting Bracket

This heavy steel bracket provides a quick and easy means to attach the Pro II Fence, the Wonder Fence, or the TS table saw fence.

9 Micro Adjust Knob

With the carriage clamp in the micro adjust position, use this knob to fine-tune the location of your fence in $\frac{1}{1000}$ " increments ($\frac{1}{40}$ mm for metric version.) Ball bearing engaged detents on the knob provide an audible click for each $\frac{1}{1000}$ " ($\frac{1}{20}$ mm) of adjustment. The pointer and easy to read scale give a clear

readout of your fence movement. Turning the knob clockwise moves the fence closer to the cutter. Turn it counterclockwise and the fence moves away from the cutter. Each full turn of the knob moves the fence $\frac{1}{32}$ " or 1mm for the metric version.

10 Micro Adjust Scale Dial

This laser engraved dial provides a clear reference for micro adjustments. Each mark on the dial represents $\frac{1}{1000}$ " ($\frac{1}{40}$ mm for metric version.) After micro adjusting, the dial can be re-zeroed to the pointer for future adjustments.

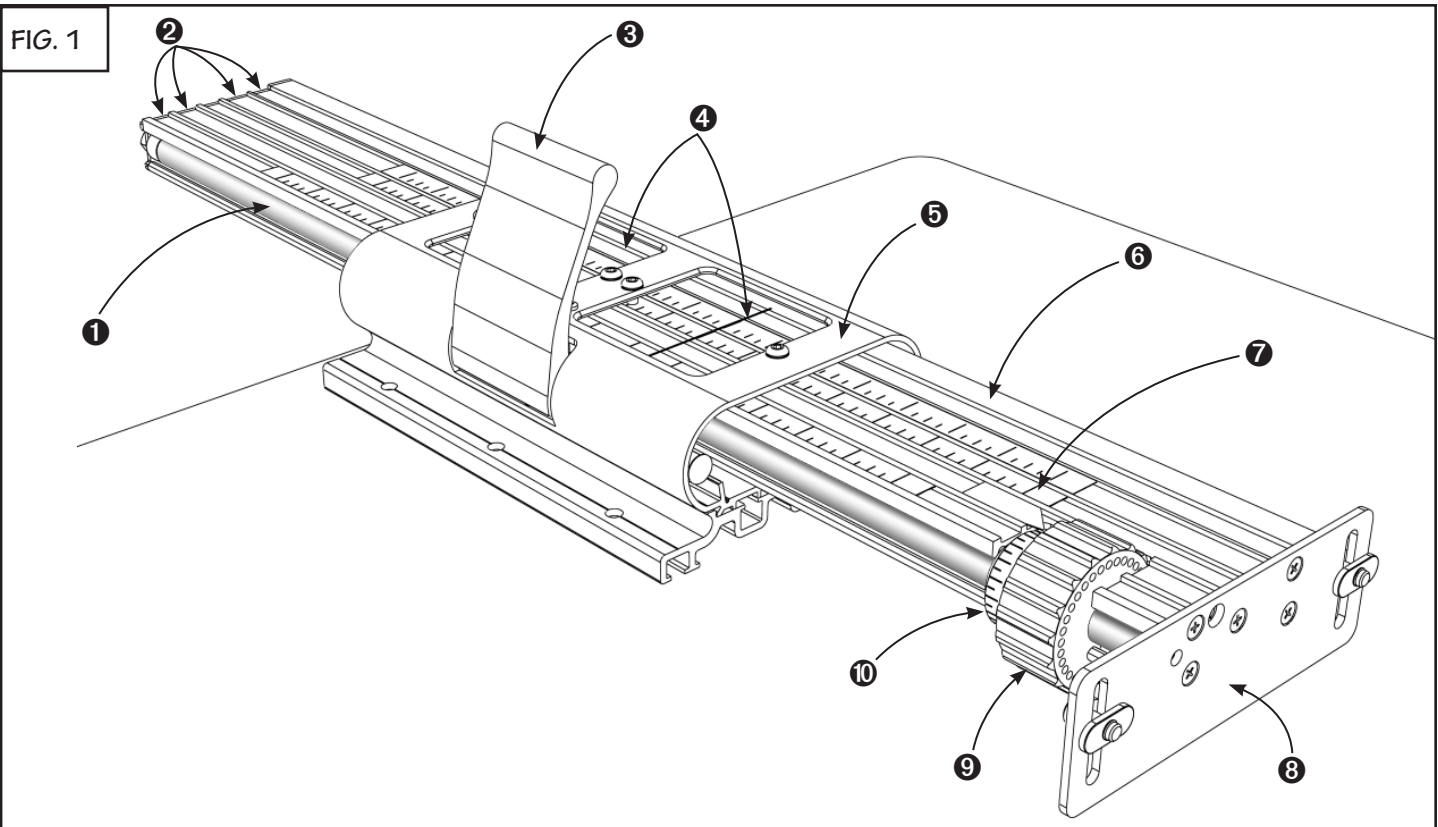

SETUP - MOUNTING TO YOUR ROUTER TABLE

Note: If you are setting up a table saw-based LS, read the *Getting Acquainted* and *Operations* section of this manual, then follow the instructions in the TS-LS owner's manual.

1 Drill Mounting Holes

Unlock the carriage clamp and carefully remove the carriage from the LS base. For maximum access to fence system range, locate the leading edge of the LS base the following distance from the center of your router collet: $19\frac{3}{4}$ " for the 17" (430mm) range model or $27\frac{3}{4}$ " for the 25" range model, Fig. 2. Center the LS Base across the width of your table. If you have a router table top that is not long enough to handle the full range of your **LS Positioner**, see the **Tip** on page 6 for an easy way to extend your table dimensions.

Note: While it is permissible to allow some of the LS Base to overhang the table, a minimum of 4" of the LS Base must be overlapped onto the table for secure mounting.

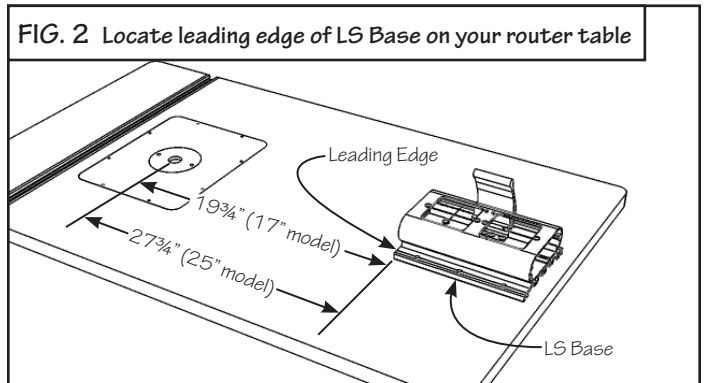

TIP

Extending your router table length

Screw aluminum or steel angle to the underside of the router table to provide support arms for a table extension, **Fig. 3**.

The extension needs to be flush and parallel to the table top. Shim into alignment as necessary.

Once you have determined where the leading edge of the LS Base will be positioned, mark a line on the table at this spot. The line should be parallel to the back edge of your router table. Measure back 1" from this line and mark positions for (2) $\frac{5}{16}$ " diameter mounting holes spaced $5\frac{1}{2}$ " apart. Measure back another 2" further and mark positions for (2) more $\frac{5}{16}$ " diameter holes, **Fig. 4**. (If your table permits, increase the spacing between the 2 sets of holes.) Drill the holes.

2 Attach LS Base to your Router Table

Open the **LS Base Mounting Hardware Pack A-21**. Place the (4) $\frac{1}{4}$ -20 x 2" hex bolts through the holes in the table and loosely fasten with $\frac{1}{4}$ " washers and hex nuts. Now slide the heads of the bolts into the T-slot located on the underside of the LS Base, **Fig. 5**. Square the base to your table edge and tighten the fasteners. Now slide the carriage back into the base and pull the carriage clamp up to lock the carriage in place.

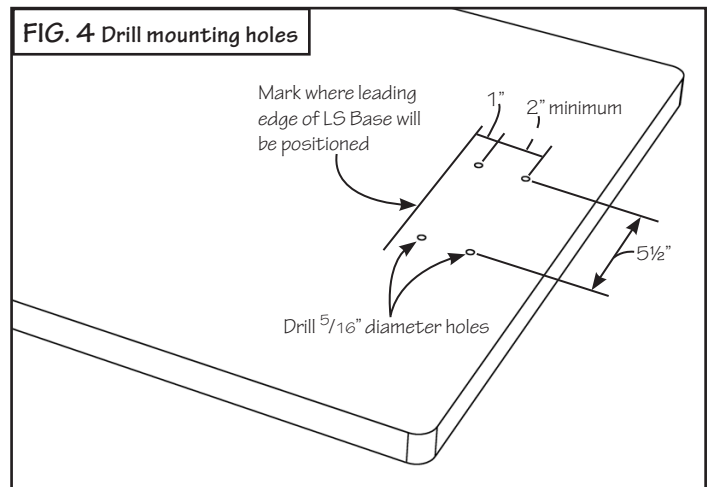
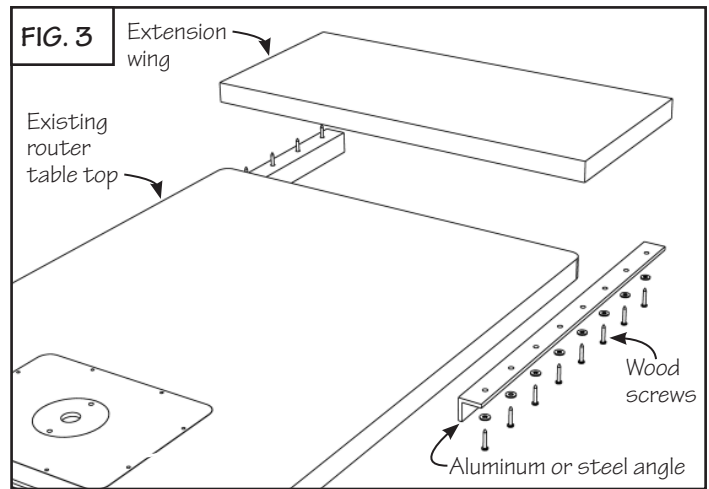
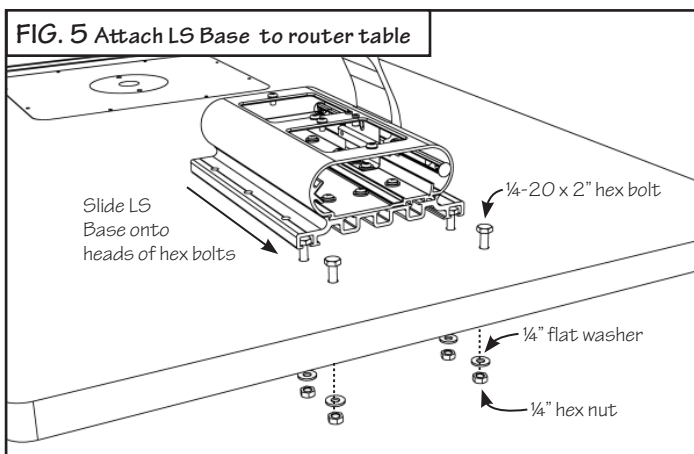

Note: If you have an "Inkra ready" router table with T-nuts installed in the pre-drilled mounting holes, use the (6) $\frac{1}{4}$ -20 x $1\frac{3}{4}$ " pan head Phillips screws with $\frac{1}{4}$ " washers to attach the LS Base as shown in **Fig. 6**.

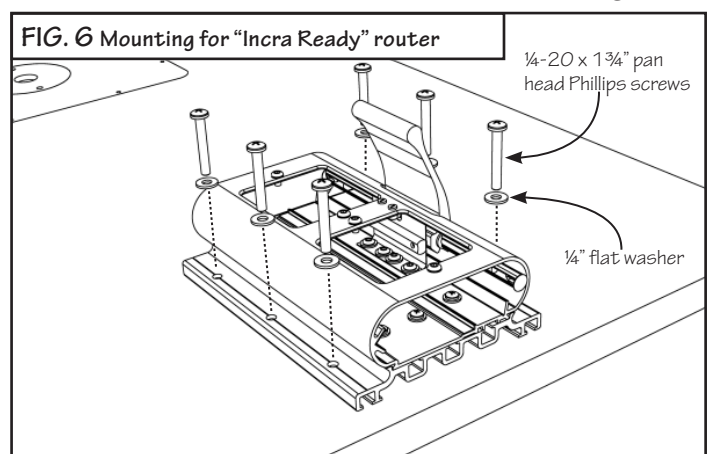

PRO II FENCE INSTALLATION (STANDARD & SUPER

The Pro II Fence, included in both the Standard and Super System packages, provides a 28" long reference for all of your cutting operations. Machined to perfection, it includes a 1" x 1" opening to handle all of your grooving, dadoing, rabbeting and joinery applications. The fence top includes INCRA positioning racks that work in conjunction

with the INCRA Shop Stop for perfectly repeatable stopped cuts. The self-storing stop extender bar permits stopped cuts beyond the length of the fence and the front T-slot allows easy attachment of user-made sub fences or the Super System Wonder Fence.

Attaching the Pro II Fence

Carefully slide the carriage into the LS Base and pull the carriage clamp up into the fully locked position. Open the **Incra Pro II Fence Hardware Pack A-07**. Place a $\frac{1}{4}$ " washer on each of the (2) $\frac{1}{4}$ -20 x $\frac{1}{2}$ " socket head screws and insert through the slotted holes located on the steel fence mounting bracket. Loosely thread on the $\frac{1}{4}$ -20 rectangular nuts, then slide the nuts into the T-slot located on the rear of the Pro II Fence. Position the fence so that the carriage is approximately centered on the fence length and tighten the (2) mounting screws with the supplied hex tool, **Fig. 7**.

Installing Pro II Extender Bar and Stop

Place a $\frac{1}{4}$ " washer on the $\frac{1}{4}$ -20 x $\frac{3}{8}$ " socket head screw and insert through one of the holes located at either end of the Pro II Fence. Loosely thread on the $\frac{1}{4}$ -20 rectangular nut and slide the extender bar into the cavity in the fence, capturing the rectangular nut in the T-slot located on the extender bar. The scale on the extender bar should be face up. Slide the extender bar until only about 1" of the bar remains exposed and tighten the fastener, **Fig. 8**.

Place a $\frac{1}{4}$ " washer and a $\frac{1}{8}$ " thick nylon washer on the $\frac{1}{4}$ -20 x 2" socket head screw, insert through the extruded hole located on the extender bar stop, and loosely thread on the $\frac{1}{4}$ -20 rectangular nut. Slide the nut into the T-slot located on the front of the extender bar. Slide the extender bar stop until the flat side of the stop contacts the end of the Pro II Fence. Tighten the fastener, then slide the scale to read 0" at the end of the fence extrusion, **Fig. 9**.

FIG. 9 Install extender bar stop

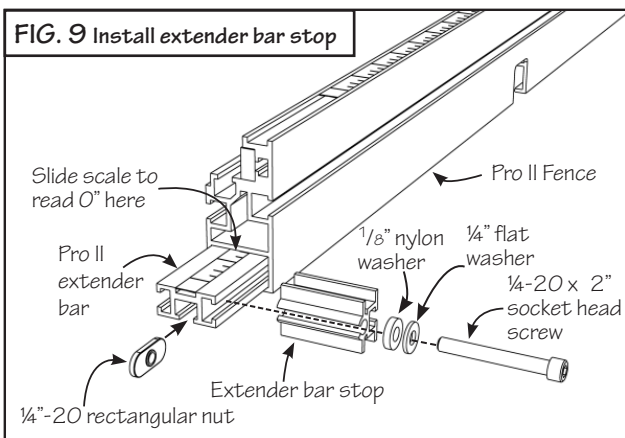

TIP When not in use, the extender bar and stop can be stored in the fence. Just slide the extender bar out, turn it over so that the scale is face down, and insert back into the fence. Tighten the fastener to secure the bar, **Fig. 10**.

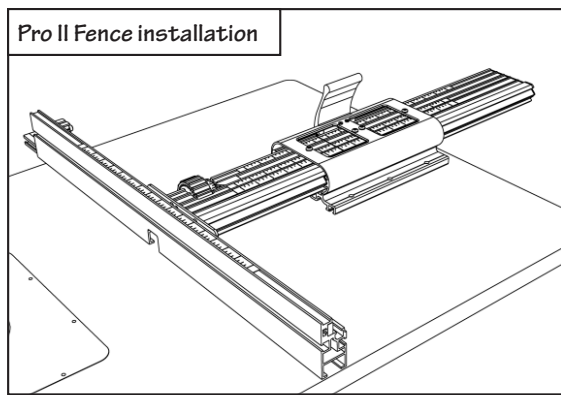

FIG. 7 Attach Pro II Fence

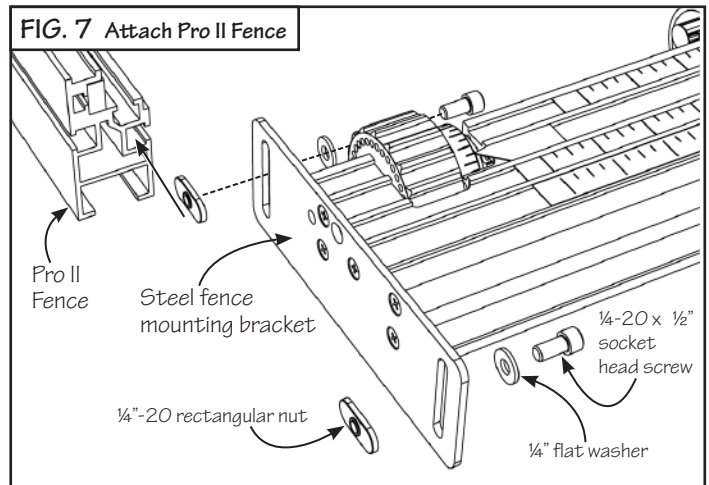

FIG. 8 Install Pro II extender bar

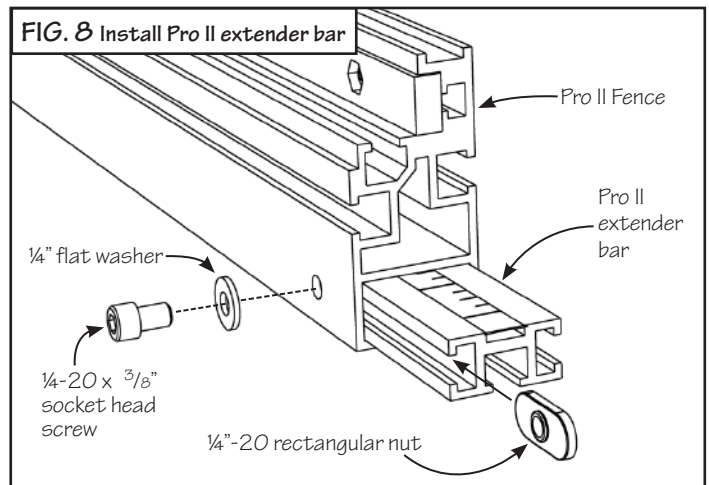
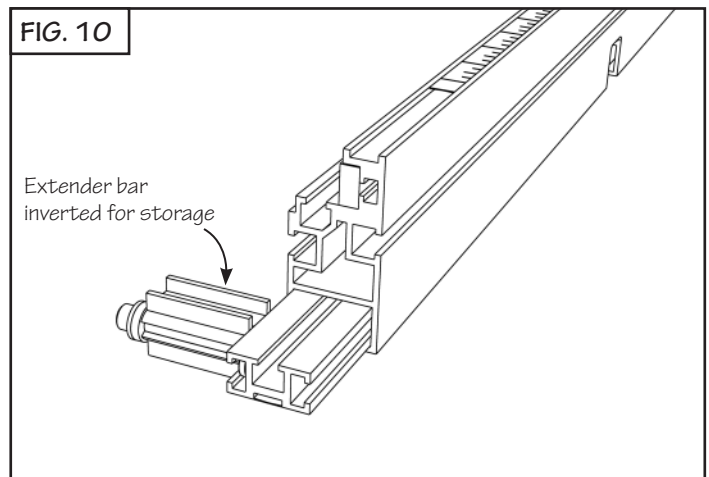

FIG. 10



Adjusting the Fence Angle

After mounting the Pro II Fence, pull the carriage clamp up to the fully locked position and check the angle of the fence to your tabletop using a reliable square. Any deviation from 90° can be adjusted to perfection by placing a masking tape shim between the mounting bracket and the fence as shown in Fig. 11.

Mounting an Auxiliary Fence to your Pro II Fence

Should you have an application requiring the use of a user-made wooden auxiliary fence, you'll find the T-slot in the front face of the Pro II Fence is designed to capture a $\frac{1}{4}$ -20 hex nut. Just use the dimensions in Fig. 12 to drill and counterbore the fence, then use (2) $\frac{1}{4}$ -20 Phillips pan head screws, (2) $\frac{1}{4}$ " flat washers, and (2) $\frac{1}{4}$ -20 hex nuts to secure the auxiliary fence to the Pro II Fence. Adjust the length and thickness of the fence to accommodate your application.

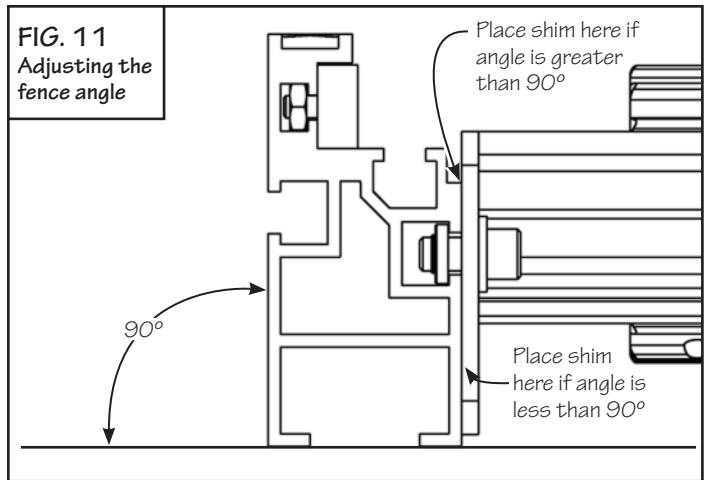
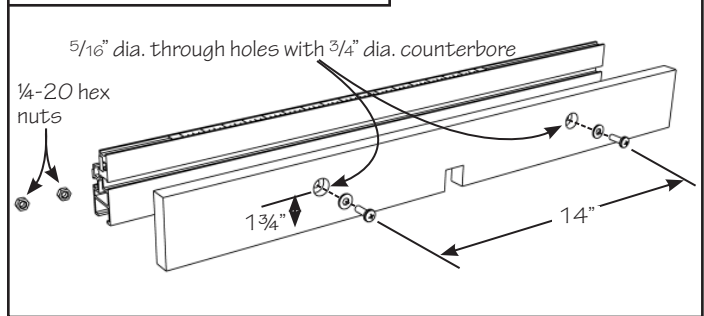

FIG. 12 Mounting an auxiliary fence



WONDER FENCE INSTALLATION (SUPER SYSTEM ONLY)

While you should read the *Safety, Operation and Applications* sections of the included Wonder Fence owner's manual, it is not necessary to read the Fence and Hi-Rise mounting instructions in that manual. Just follow the instructions below for proper mounting of the Wonder Fence and Hi-Rise Fence Cap to your LS Positioner.

Attaching the Wonder Fence to the Pro II or TS Fence

Note: In the 17" (430mm) and 25" Super System packages, the Wonder Fence front fence halves are shipped already installed onto the Pro II Fence; however, you should read and become familiar with the following installation procedure for future adjustments or removal.

Insert the supplied hex tool through the (2) large diameter access holes located on the front of each Wonder Fence half and loosen the (2) socket head screws. Do not remove the rectangular nuts. For a better view of the fasteners, loosen the thumbscrew and slide the black plastic view panel located on the top of each fence half, Fig. 13.

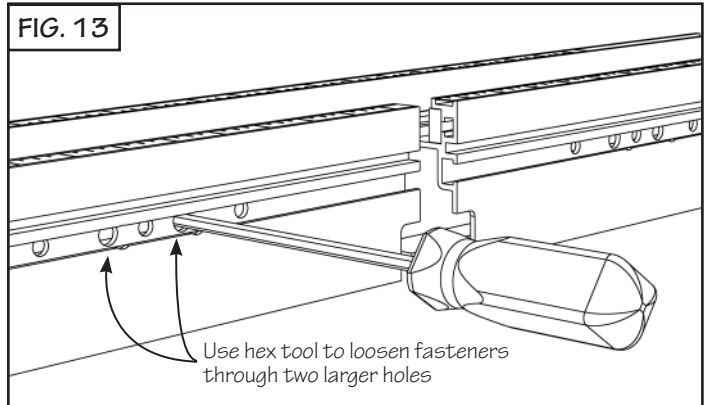
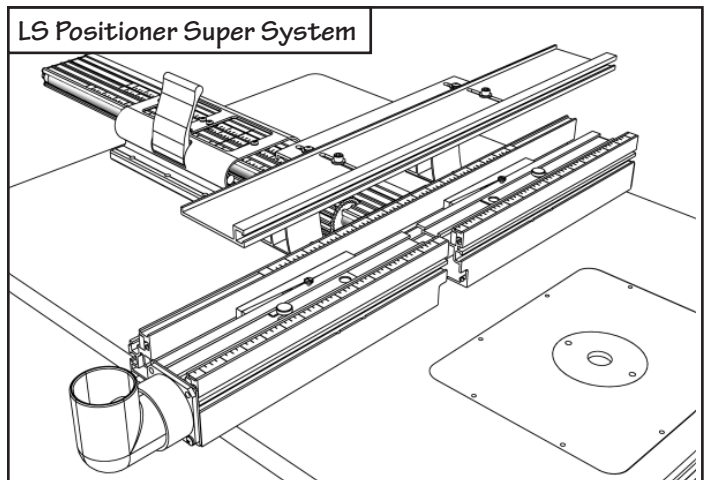

Slide the (2) rectangular nuts on each Wonder Fence half into the T-slot located on the front face of the Pro II, **Fig. 14** or the TS Fence, **Fig. 15**. Position the Wonder Fence halves so that your router collet

is centered in the opening between the fences, then tighten the (2) socket head screws on each fence half. Slide the view panel back in place and tighten the thumbscrew.

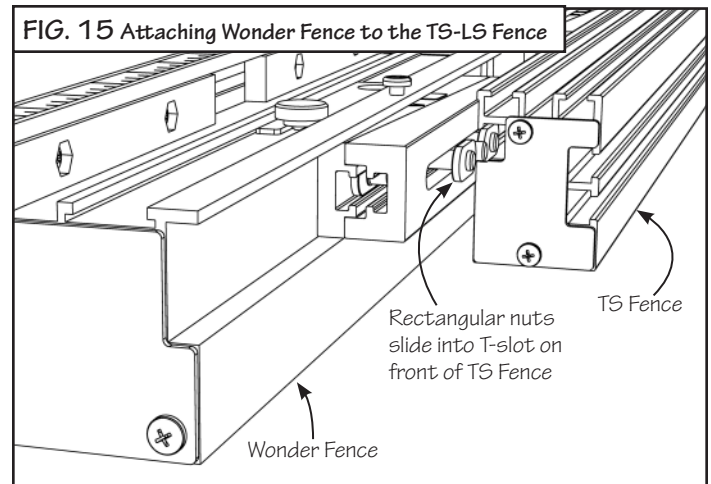
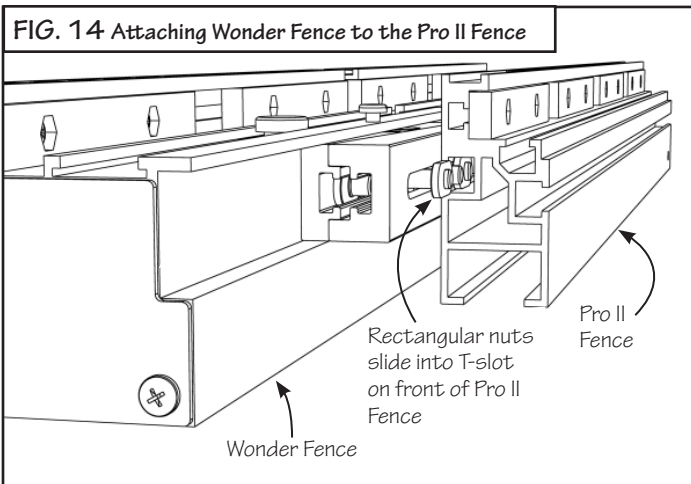

Attaching the Wonder Fence Hi-Rise Fence Cap

1 Attach the Fence Cap Braces

Open the **Wonder Fence Hi-Rise Fence Hardware Pack A-09**. Place a $\frac{1}{4}$ " washer on each of the (2) $\frac{1}{4}$ -20 x $\frac{3}{8}$ " button head screws and loosely thread one screw into each of the (2) dual pilot rectangular nuts. Place a $\frac{1}{4}$ " washer on a $\frac{1}{4}$ -20 x $\frac{1}{2}$ " socket head screw and insert through the hole on the front of each fence brace. Loosely thread the screw into the remaining hole on the dual pilot rectangular nut, **Fig. 16**. Repeat for the remaining fence brace and dual pilot nut.

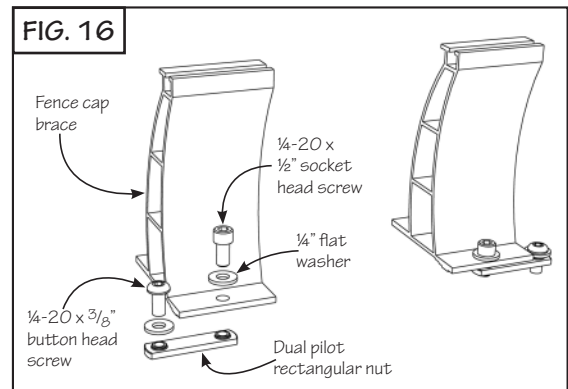

Slide the dual pilot nut on each fence brace assembly into the T-slot located on the top of the Pro II Fence. Use the forward T-slot located on the TS Fence. Space the two braces $7 \frac{5}{8}$ " apart on the fence. Tighten all (4) fasteners, **Fig. 17**.

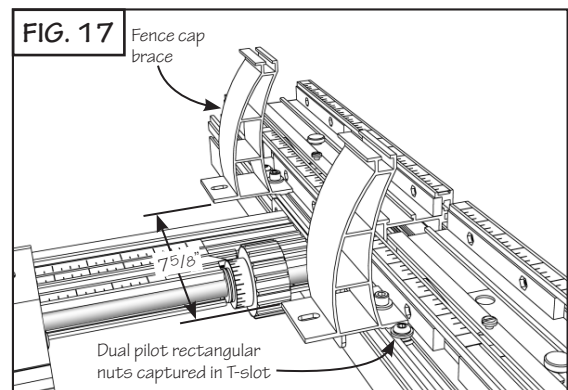

Open the **Wonder Fence Brace Support Hardware Pack A-10**. Place a $\frac{1}{4}$ " washer on each of the (2) $\frac{1}{4}$ -20 x $\frac{1}{2}$ " socket head screws supplied and insert through the slotted holes located on the support brackets. Loosely thread on a $\frac{1}{4}$ -20 rectangular nut, then slide the nut into the T-slot located on the rear of the Pro II Fence.

Position the support brackets directly under the fence cap braces. Slide the support brackets up to firmly contact the underside of the fence cap braces, then tighten the socket head screws, **Fig. 18**.

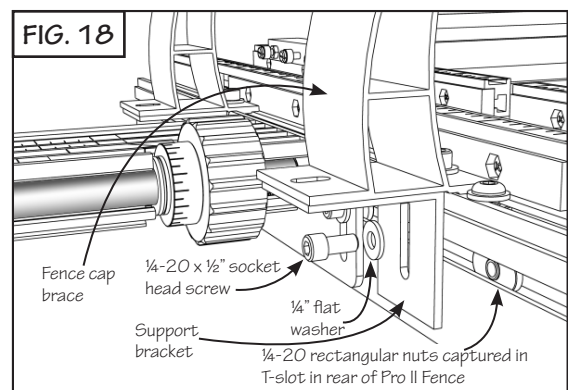

Note: Support brackets are not required for use on the TS Fence.

2 Attach the Cap Extender

Place a $\frac{1}{4}$ " washer on each of the (2) #10-32 x $\frac{1}{2}$ " Phillips pan head screws and insert through the slotted holes located in the fence cap extender. Loosely thread a #10-32 hex nut onto each fastener, then slide the hex nuts into the T-slot located on the top of each fence cap brace. Position the cap extender so you can later gain access to the socket head fasteners on each fence cap brace through the slotted holes. Pull the cap extender forward until it firmly contacts the back of each brace and tighten the (2) Phillips head screws. See **Fig. 19** and **Detail 19A**.

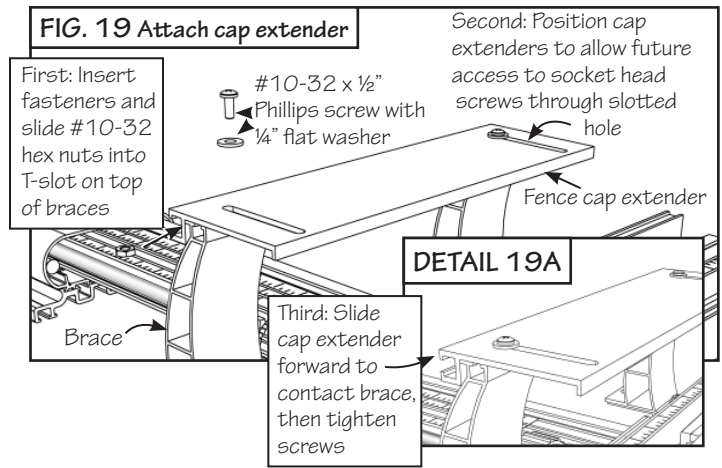

3 Attach and Align Fence Cap

Place the 24" long fence cap on top of the cap extender and attach using the (2) $\frac{1}{4}$ -20 x $\frac{5}{8}$ " socket head cap screws with $\frac{1}{4}$ " washers and lock nuts. Use a straightedge to align the leading edge of the fence cap with the front face of the Wonder Fence and tighten the two cap mounting screws, **Fig. 20**. To remove the fence cap and braces, just remove the two fasteners that secure the braces to the top of the Pro II or TS Fence and lift the entire unit off, **Fig. 21**. Place the fasteners back into the threaded holes in the dual pilot rectangular nuts for storage.

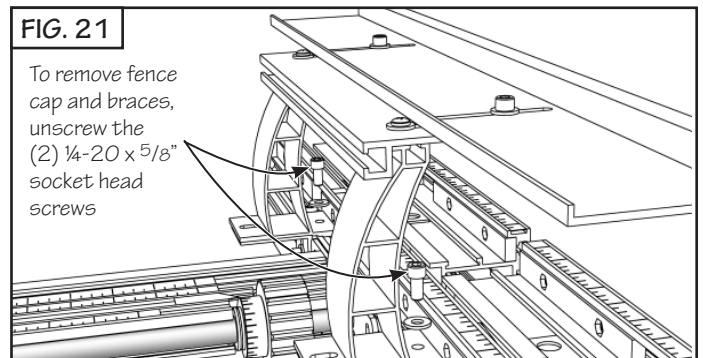
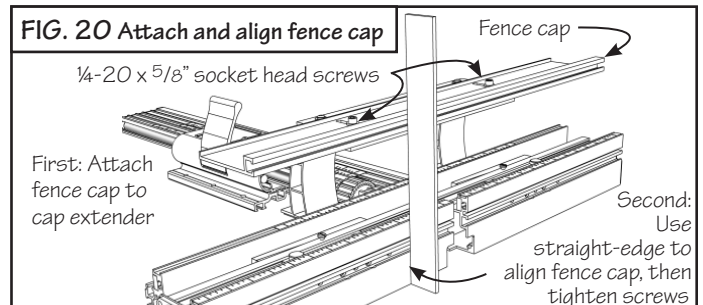

SHOP STOP

When used in conjunction with your new Pro II Fence or Wonder Fence, the INCRA Shop Stop provides the same precise positioning capabilities that your LS Positioner offers. The patented incremental positioning of INCRA's saw-toothed racks found on the Shop Stop and your INCRA fence allow perfectly repeatable stop locations at any multiple of $\frac{1}{32}$ " (1mm for metric version.) The two-piece body can be micro adjusted to any position between steps and can be configured to clamp up to your fence even when using wooden sub fences up to $\frac{3}{4}$ " thick. Follow the instructions on the next page to set up and use the Shop Stop.

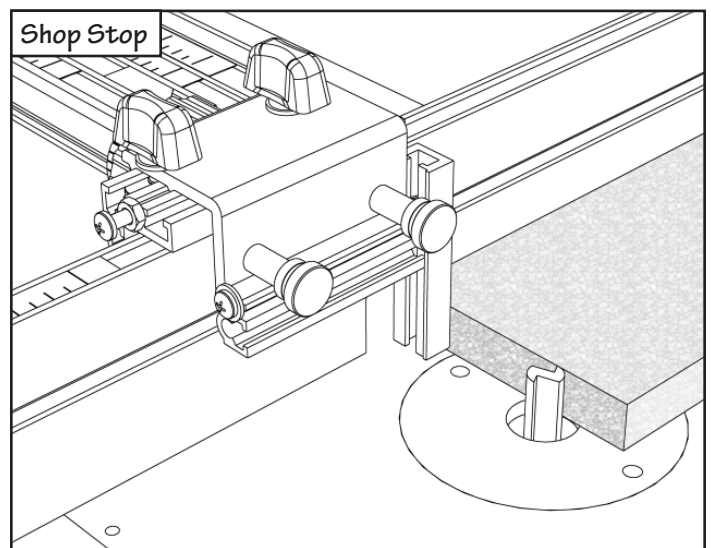

Shop Stop Assembly

After removing the Shop Stop from the packaging, loosen the two white nylon thumbscrews and clamp the stop to the outfeed end of your INCRA fence. Now loosen the #10-32 x 3½" Phillips head screw and slide the red vertical stop arm onto the hex nut, **Fig. 22**.

Make sure that the indexing lip on the arm wraps around the front of the stop body and that the arm is flat against the end of the body, **Fig. 23**. Tighten the fastener to secure the arm a short distance above your router table to provide clearance for sawdust.

The fastener and stop arm can be reversed for use at either end of your fence.

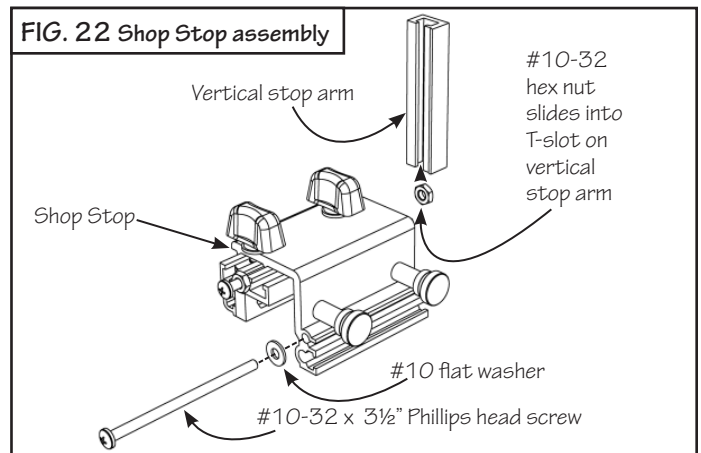
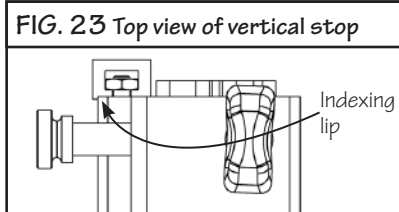

Micro Adjusting

Fine-tuning the position of your Shop Stop relative to a cutter is easy and accurate. Just loosen the two black thumbscrews on top of the Shop Stop body about 1/8 turn, then turn the machine screw located at the end of the stop, **Fig. 24**. Each full turn of the screw moves the stop surface exactly 1/32" (approx. 1mm.) When turning the screw counterclockwise, push the stop body toward the screw. Always tighten the two black thumbscrews after micro adjusting.

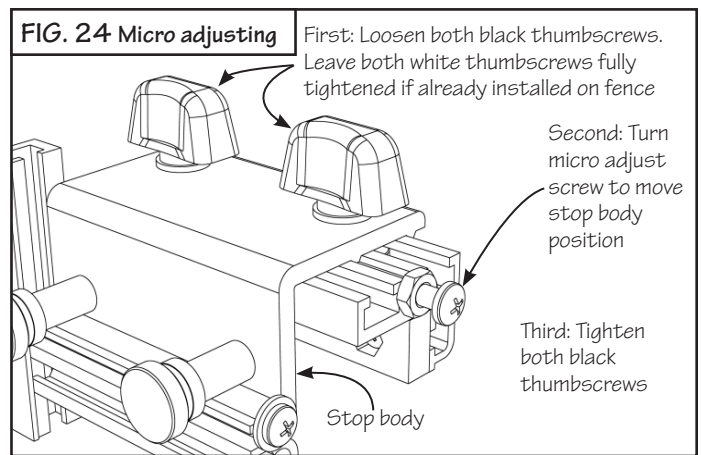

Expanded Clamping Mode

The two-piece design of the INCRA Shop Stop permits use of a ¾" thick wooden auxiliary fence without interfering with the stop's ability to clamp to your INCRA Fence. To change the stop to expanded clamping mode, loosen the two black thumbscrews and slide the stop body (red) off of the stop cap (gold). Now slide the (2) rectangular nuts on the stop body into the alternate T-slot on the cap, **Fig. 25**. Tighten the two clamping knobs.

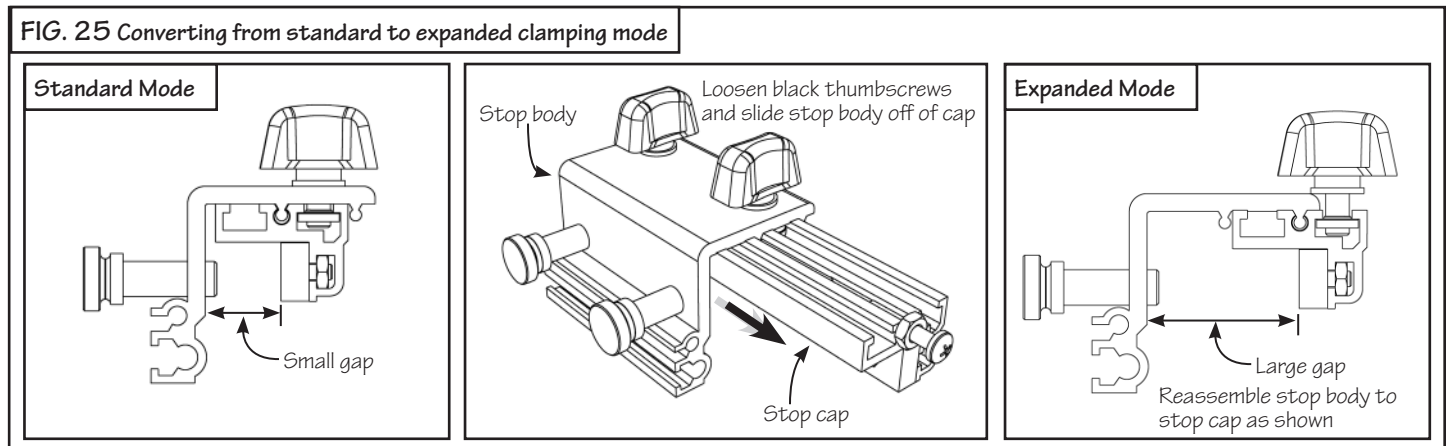

Zeroing the Shop Stop

In order for your INCRA Shop Stop to accurately locate your work piece for a cut, you must first “zero” your Shop Stop to the cutter and position the sliding scale on your fence. For most applications at the router table you will be using your Shop Stop on the outfeed fence to limit the length of a cut relative to the front end of a board. Follow the steps detailed in **Fig. 26** to zero to your cutter.

Once the Shop Stop is zeroed to the router bit as shown in Fig. 26, you now have the choice of setting the sliding scale on your INCRA Fence to one of three initial positions. See **Fig. 27** and **Detail 27A**.

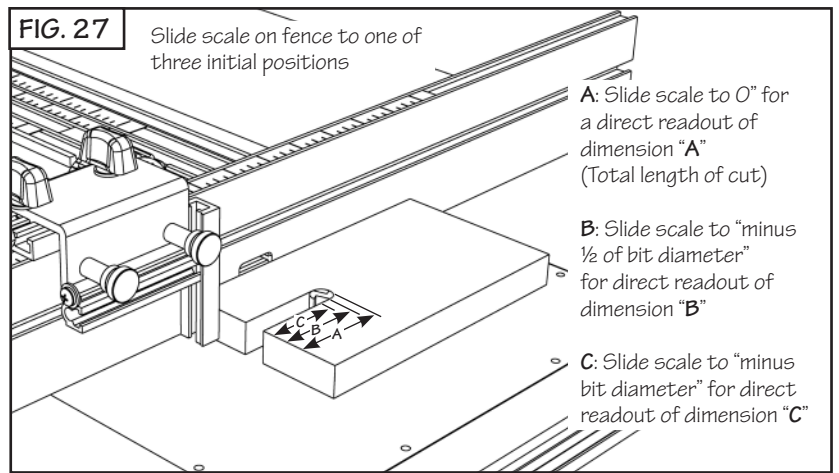
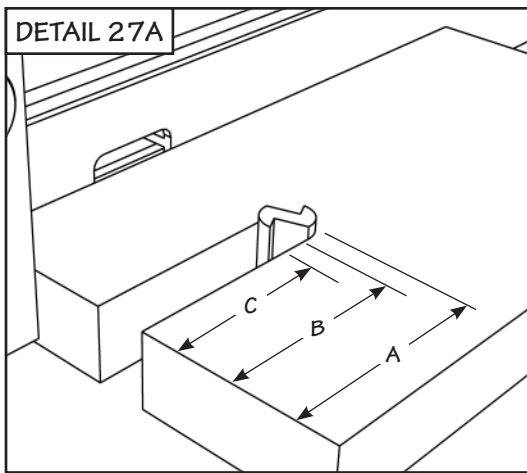
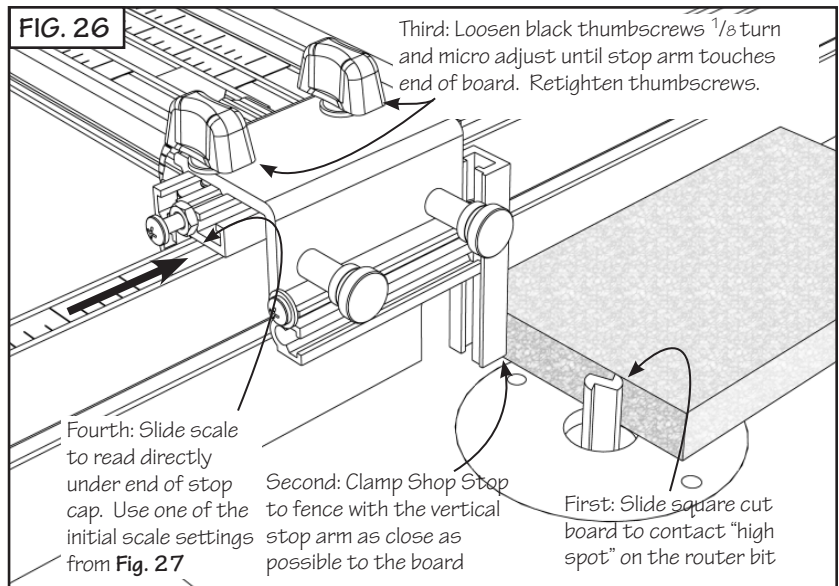

OPERATION

Moving to a New Scale Setting

Moving the fence to any new scale setting is just as easy as moving any other fence you’ve used before. Push the carriage clamp down to unlock the carriage, then slide the fence as you sight through the hairline cursor. When you see your measurement under the hairline cursor, pull the clamp up to the locked position, **Fig. 28**. Remember that the LS Positioner will only clamp every $\frac{1}{32}$ " or 1mm with the metric version, so don’t try to clamp in between scale marks. It just won’t work!

TIP

Although the clamping pressure has been factory adjusted, you may wish to fine-tune the pressure to suit your individual feel. If so, use the thin plastic shims provided and follow the instructions beginning on page 14.

CAUTION: For your safety, keep your hands behind the fence when moving to any new scale setting.

FIG. 28 Moving to any new scale setting

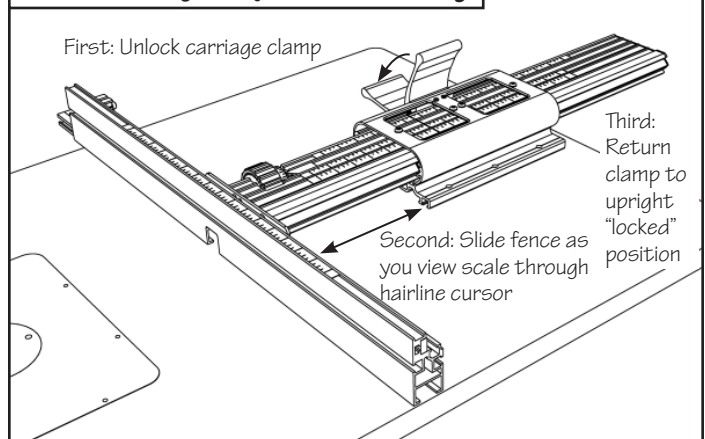

Micro Adjusting your Fence Position

The micro adjust feature of your LS Positioner allows for precise positioning of the fence to any location between the $\frac{1}{32}$ " or 1mm incremental spacing of the lead screw. You'll find this feature extremely handy the next time you need to widen a mortise by a hair for a great fitting mortise and tenon joint. Use the micro adjuster for a flawless fit when cutting grooves to accept inlay strips or to loosen up a tight fitting tongue and groove joint. You'll find it especially useful for setup operations like "zeroing" to your cutter, or "centering" for joinery. Here's a step-by-step look at operating your LS Positioner's micro adjuster. See Fig. 29 as you follow the steps.

1 Set Carriage Clamp to Micro Adjust Position

Lower the carriage clamp to completely unclamp the carriage, then raise the carriage clamp to the center position. This center position for the carriage clamp softens the clamping pressure on the carriage to permit movement during micro adjusting.

2 Micro Adjust the Fence Position

Rotate the red micro adjust knob located at the forward end of the carriage. Turn the knob clockwise to move the fence toward the cutter, or counterclockwise to move the fence away from the cutter. Ball bearing engaged detents on the knob provide an audible click for each $\frac{1}{1000}$ " ($\frac{1}{20}$ mm for metric version) of fence movement.

3 Lock the Carriage Clamp

Pull the carriage clamp up to lock the carriage in place. Gauging the distance moved when micro adjusting is easy. A full turn of the knob equals $\frac{1}{32}$ " (1mm for metric version.) For smaller adjustments, the black dial is marked in $\frac{1}{1000}$ " ($\frac{1}{40}$ mm) increments. After micro adjusting, you can re-zero the dial to the pointer by rotating the dial (not the red knob) with your fingers. See Fig. 30.

Zeroing the Fence to Your Cutter

In order to ensure accurate cutting results from any fence for general purpose routing, the fence must first be "zeroed" to the cutter, Fig. 31. To zero your fence, unlock the carriage clamp and slide the fence up to the edge of the cutter. Sight down the length of the fence to check for a gap between the fence and the cutter. Fine-tune any remaining distance by micro adjusting the fence position. When the gap of light disappears, the cutter will be "zero" distance from the fence. Check to make sure that the router bit is safely centered in the opening in the fence. Return the carriage clamp to the locked position, then slide the measuring scale to read 0" under the hairline cursor.

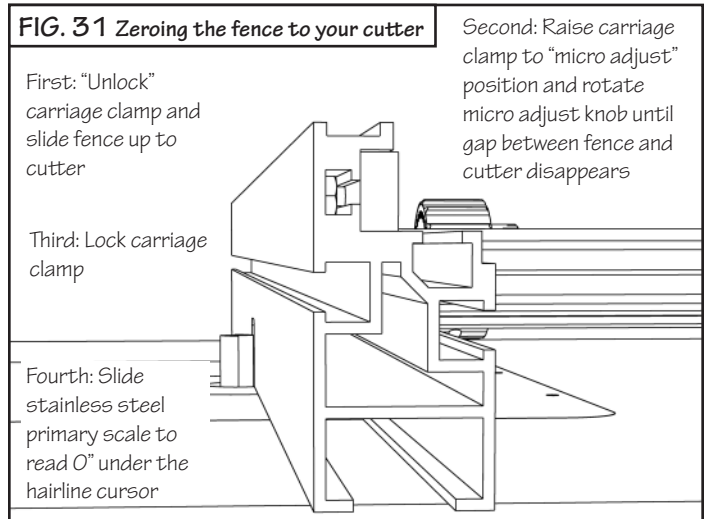
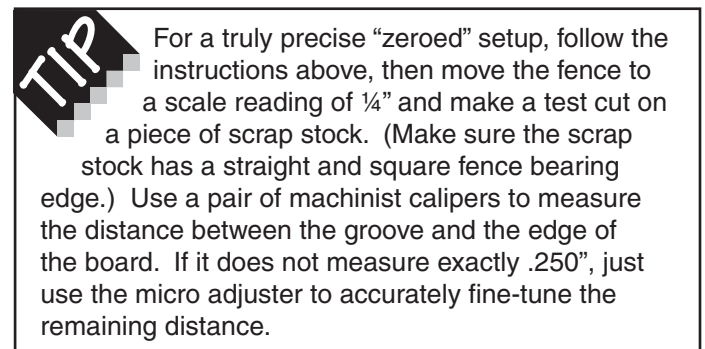
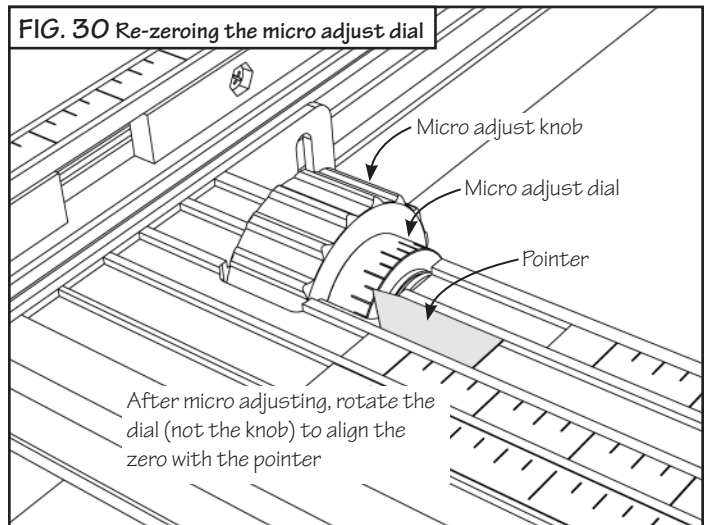
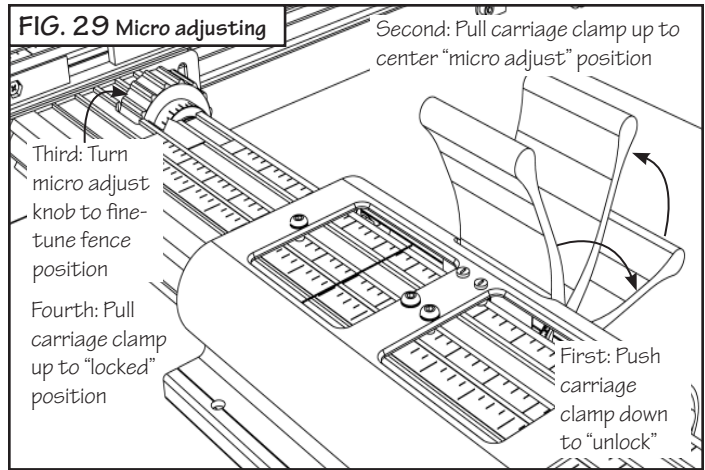

APPLICATIONS

General Purpose Fence

The essence of your INCRA LS Positioner is its ability to accurately position your board for a cutting operation. In a nutshell, it is a precision fence system. Even when used as a joint maker, you are simply applying a method of work to a very accurate fence system to produce the many possible joints. Above all else, the LS Positioner gives you the ability to make a cut exactly where you want it, **Fig. 32**.

Using your LS Positioner as a general-purpose fence is just as easy as using any other fence in your shop. In fact, it shares in common four things that all fences have: the straight edge or fence that your board will be pushed along as you make a cut, a scale, a hairline cursor, and a clamp. You will use your LS Positioner as you would any fence. That is, first you'll unclamp the carriage, then you'll look through the hairline cursor as you move the fence. When you see your measurement come under the hairline, you'll clamp the fence in place.

Of course, this is where the comparison ends because unlike other fences, when you clamp the LS Positioner in place, it is exactly where you want it to be. Just get the mark on the scale close to the hairline cursor and the Automatic Positioning Control™ of the patented Lead Screw mechanism moves the fence to the exact location as you pull the carriage clamp up to lock the fence in place. It really is that easy. You're sure to find many cutting situations in your shop where the precision of the LS Positioner will benefit you and your work.

FIG. 32 Incra LS Positioner

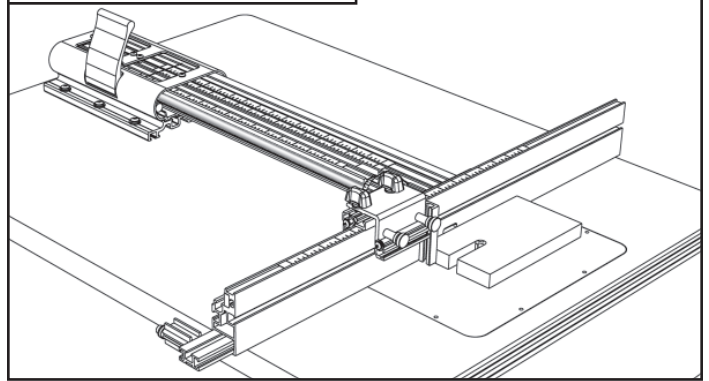

Joint Making

Joint making represents one of the most exciting applications for your INCRA LS Positioner. Just by applying a little technique to the considerable precision of the LS Positioner, you'll be able to add joinery for box and drawer making to your list of shop skills. The INCRA Master Reference Guide & Template Library included with the Standard and Super System Packages is a complete source book for joinery, including step-by-step instructions for box joints, half blind dovetails, through dovetails, the INCRA double dovetail and the double-double box joint, **Fig. 33**.

FIG. 33 Master Reference Guide

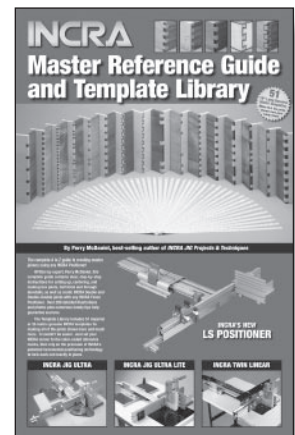

ADJUSTMENTS

All of the components and features of your new INCRA LS Positioner have been factory set and should require no further adjustment. If, however you wish to adjust or recalibrate these components, the following information is provided to assist in performing the adjustments.

Adjusting the Clamping Pressure

The LS Positioner carriage clamp assembly was designed to make it easy for the operator to adjust the

clamping pressure using the carriage clamp pad shims supplied in **Hardware Pack A-22**. Here's how: Unlock the carriage clamp and press the 1/8" thick black UHMW bearing pad forward with your finger as you use a 1/8" hex key to remove the set screw that passes through it. Slide the black UHMW bearing pad up and out of the LS Base.

Note: Do not pull the carriage clamp up with the black UHMW bearing pad removed.

You'll notice one or more thin plastic shims in the cavity behind the metal spring engager, **Fig. 34**. To change the clamping pressure, simply add or remove shims. If you want to increase clamping pressure, add one of the supplied shims. If you want to decrease clamping pressure, remove one of the thin shims. The matte finish shim is .005", the clear shim is .010" and the white shim is .020". **When making adjustments, add or remove only .005" at a time, and keep the thinner shims between the metal spring engager and the white shim, Fig. 35.** Press the metal spring engager forward with your finger and slide the black UHMW bearing pad between the shims and the carriage clamp.

Note: You will notice a piece of thick tape adhered to one face of the black UHMW clamping pad. When reinstalling the clamping pad, make sure the taped surface is facing away from the carriage clamp, **Fig. 34**.

Press the UHMW bearing pad forward and reinstall the set screw.

CAUTION: Whenever making clamping pressure adjustments, always make sure that adequate pressure remains to hold the carriage rigidly in place when clamped in the fully extended position.

Realigning the Fence Racks

To check or adjust the alignment between the INCRAs positioning racks attached to the back of your Pro II Fence, begin by loosening the fasteners securing the racks to the fence. Align the first rack flush with the end of your fence and tighten the fasteners. Now, clamp the INCRAs Shop Stop to your fence so that it bridges the gap between the ends of racks #1 and #2 as shown in **Fig. 36** and tighten the mounting screws for rack #2. Next, move the Shop Stop to bridge the gap between racks #2 and #3 and tighten the mounting screws for rack #3. Finally, bridge the gap between racks #3 and #4 and tighten the rack #4 mounting screws. This process aligns the racks so that the Shop Stop will operate accurately along the entire length of the fence. The racks on the Wonder Fence can be aligned in the same way.

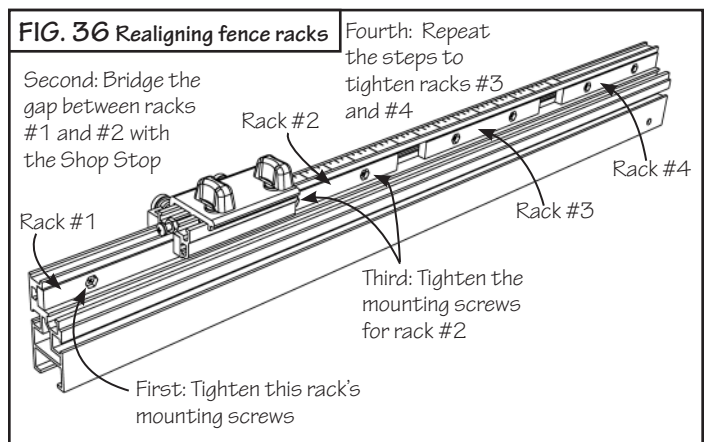
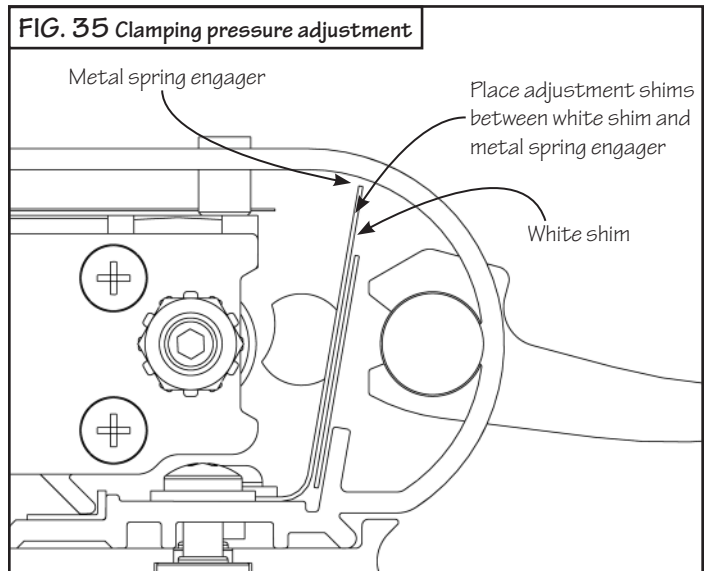
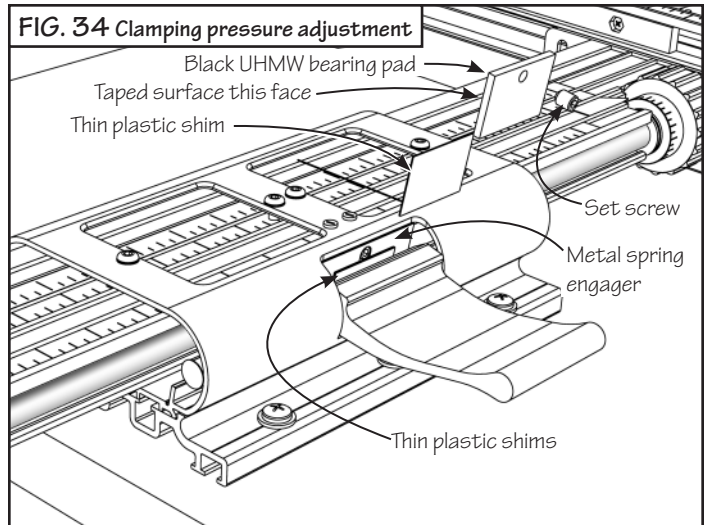

AUTO CENTERING SCALE (IMPERIAL MODEL ONLY)

Before installing any of the INCRAs joinery templates in preparation for cutting a dovetail or box joint you must first position your fence so that the router bit is aligned with the center of your board's width. This can be done using the manual "centering" method described on pages 3-4 of the INCRAs Master Reference Guide

& Template Library. The manual method does require a trial cut on a scrap of wood but it will work on any width of stock. However, if you are working with a board width that is some multiple of 1/16" you'll find the INCRAs Auto Centering Scale provides a quick and easy way to find the center that requires no trial cuts!

Positioning the Auto Centering Scale (Imperial Model Only)

- 1** Install the router bit recommended for the selected joint pattern and set the depth of cut as described on pages 2-3 of the *INCRA Master Reference Guide & Template Library*.
- 2** Zero the fence to your cutter with the router bit behind the fence rather than in front. To do this, slide your fence to cover the router bit (the bit should be inside the notch just slightly behind the front face of the fence) and place your jig in the micro adjust mode. Place a straight board against the fence and micro adjust the fence position until you see the router bit just barely touching the board, **Fig 37**. Pull the carriage clamp up to lock your jig.

- 3** Slide the INCRA Auto Centering Scale into one of the scale slots. You'll notice on the right end of the scale the words "Router Bit Diameter" and an arrow pointing to the following numbers: 1/8, 1/4, 3/8, 1/2, 5/8, 3/4, 7/8, 1. Slide the scale to position the number that matches your router bit diameter directly under the hairline cursor. **Fig. 38**

Using the Auto Centering Scale

Unlock and slide the fence until you see the dimension on the scale that matches your selected stock width directly under the hairline cursor. Lock the fence in place. **Example:** If you are centering on a 6" wide board, slide your fence until you see the 6" mark on the Auto Centering Scale under the cursor and lock the jig in place. Now slide your joinery template into one of the scale slots, position the suggested center cut mark directly under the hairline cursor and you are ready to cut the joint.

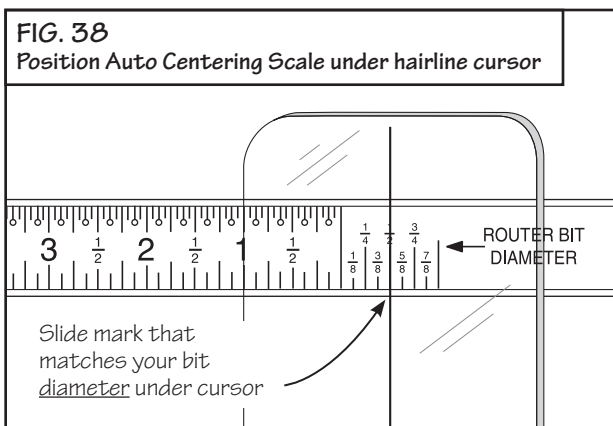
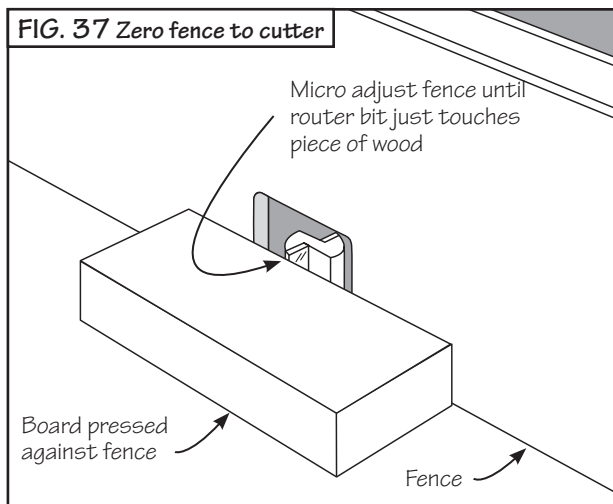

Note: Your Auto Centering Scale has marks on the top edge that are closer together than the marks on the bottom edge. When reading the scale, each mark along the top represents 1/16" of board width. Each mark along the bottom edge represents 1/8" of board width.

WARRANTY

Taylor Design Group, Inc. warrants this product for one year from date of purchase. We will repair any defects due to faulty material or workmanship, or at our option, replace the product free of charge. Please return the failing component only, postage prepaid, along with a description of the problem to the address below. This warranty does not apply to parts which have been subjected to improper use, alteration, or abuse.

02/05

Made in America by:

Taylor Design Group, Inc. ■ P.O. Box 810262 ■ Dallas, Texas 75381 ■ Tel: (972) 242-9975 ■ Fax: (972) 243-4277 ■ Web Site: www.incra.com
Printed in the U.S.A. © 2010 Taylor Design Group, Inc. INCRA is a registered trademark of Taylor Design Group, Inc.